

IMPACT CRUSHERS

McCloskey brings high quality and high production capacity to mobile impactor applications. The direct drive crusher boosts power and lowers fuel costs, and along with an optimized material flow path and open chassis for ease of maintenance, boosts production and efficiency as well.

The material flow path features sectional components wider than the last to allow an unrestricted flow without funneling or narrowing, eliminating material bridging.

The recirculating models offer versatility, allowing operators to produce a crushed and screened final product with one machine. A swing out radial return conveyor can complete 90 degrees while the machine is running for additional stockpiling.

McCloskey impactors are ideal for some of the toughest applications worldwide, including asphalt recycling, concrete recycling, rock crushing, construction and demolition.

HOPPER

Spacious hopper features liners, hydraulic locking wedges, and side locking wedges that are easily operated from the ground.

CRUSHER ROTOR

Direct drive crusher rotor via clutch for maximum power transmission.

CRUSHING CHAMBER

A powerful four bar impactor with wide feed opening boosts production.

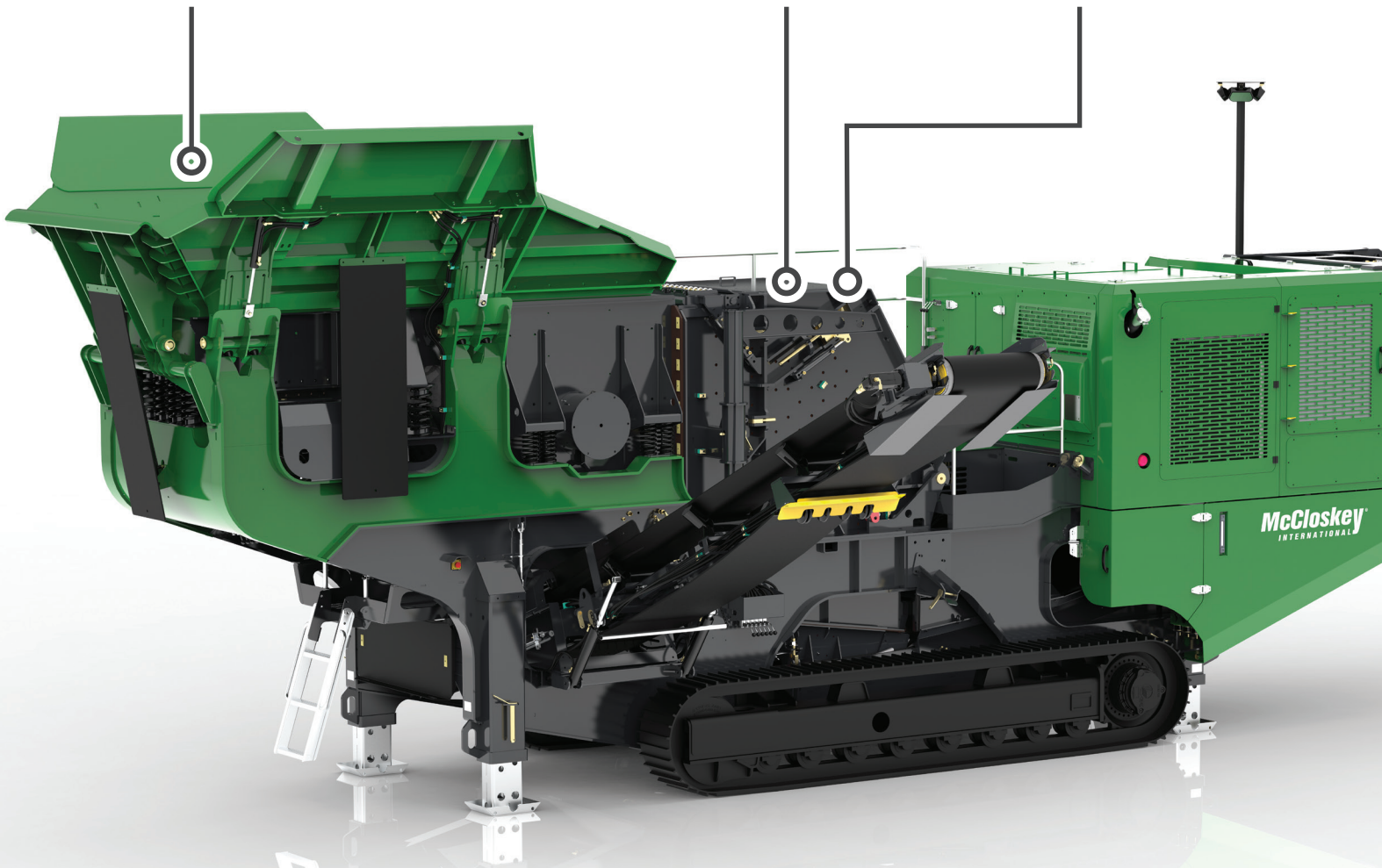

IMPACT CRUSHERS

MATERIAL FLOW PATH

Each sectional component is wider than the last to allow an unrestricted flow of material without narrowing allows for reduced wear and eliminates material bridging.

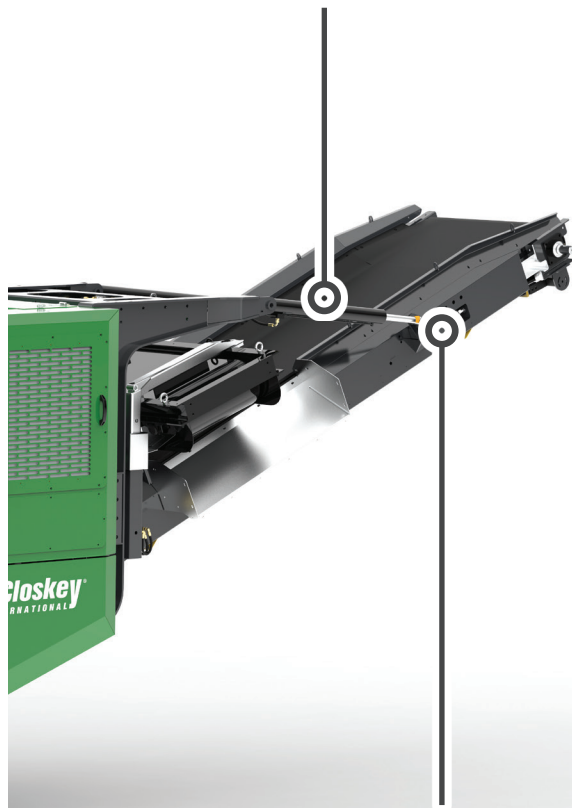

MAIN CONVEYOR

Wide main conveyor assures better output. Conveyor lowers and raises hydraulically.

- Powerful engine
- Direct drive crusher rotor via clutch which boasts maximum power transmission with a low fuel cost
- Impactor chamber with speed sensor features optimum side wall angles to allow better material flow through
- Integrated high capacity hydraulic folding hopper with liners, hydraulic locking wedges, and side locking wedges that are easily operated from the ground.
- Wide main conveyor lowers and raises hydraulically
- Material Flow Path features sectional components wider than the last to allow an unrestricted flow of material without narrowing. Allows for reduced wear and eliminates material bridging.
- Crushers come with optional chutes on all conveyors to minimize spillage and better handle material
- Pan feeders have chutes with steeper angles to reduce material sticking, heavy duty bofar design and heavy duty wear plates at the discharge
- Integrated hydraulic folding stockpiling conveyors.
- I-beam plate fabricated chassis construction
- Open chassis design for ease of maintenance
- Fast setup time

I3C IMPACT CRUSHER

Impact Rotor 35.4" (900mm) diameter
x 32.3" (820mm) wide

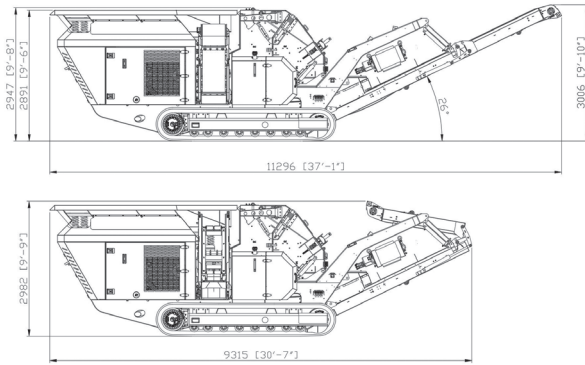

I44 IMPACT CRUSHER

Impact Rotor 41.3" diameter
x 44.3" wide

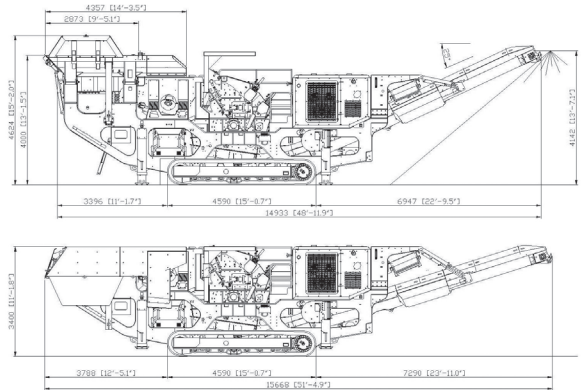

I4C IMPACT CRUSHER

Impact Rotor 41.3" diameter
x 44.3" wide

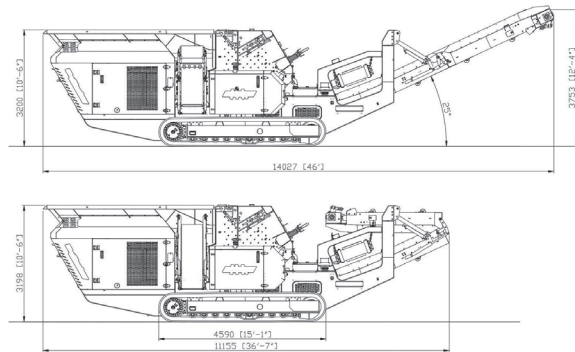

I54R IMPACT CRUSHER

Impact Rotor 47.2" (1200mm) diameter
x 52.6" (1335mm) wide

